

**MTD-50**

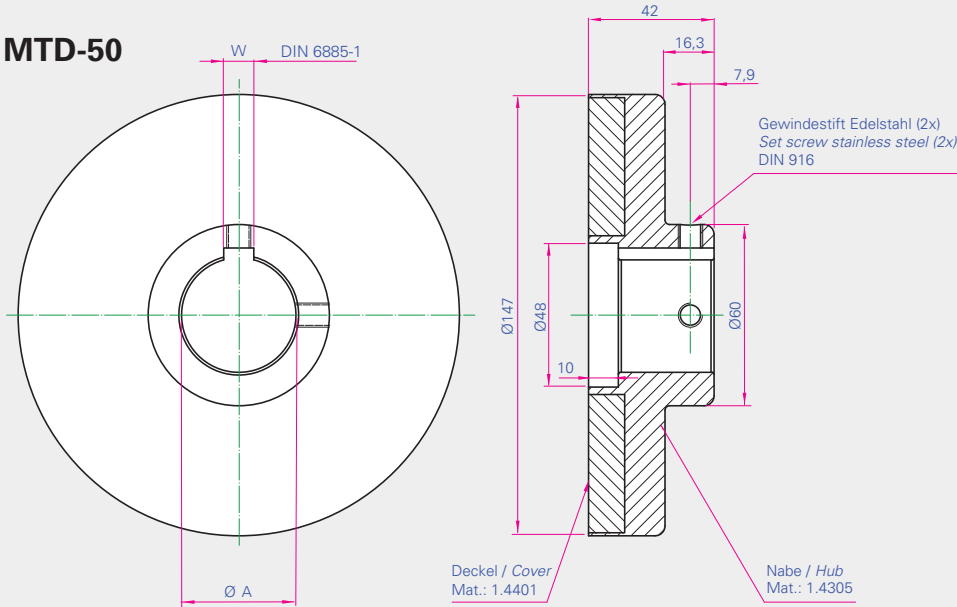

**Technische Daten**  
**Technical Specifications**

| Typ<br>Type    | Max. Geschw<br>Speed<br>(rpm) | Gewicht pro Hälfte<br>Weight per Hub<br>(kg) |
|----------------|-------------------------------|--|
| <b>MTD-400</b> | 7800                          | 3,1  |

| Typ<br>Type      | Bohrung<br>Bore<br>Ø A (mm) | Passfeder<br>Keyway<br>W (mm) | Gewindestift<br>Set Screw |
|------------------|-----------------------------|-------------------------------|---------------------------|
| <b>MTD-50-25</b> | 25H7                        | 8                             | M8                        |
| <b>MTD-50-30</b> | 30H7                        | 8                             | M8                        |
| <b>MTD-50-35</b> | 35H7                        | 10                            | M8                        |
| <b>MTD-50-38</b> | 38H7                        | 10                            | M8                        |

**Leistungsdaten**  
**Performance Data**  
**MTD-50**

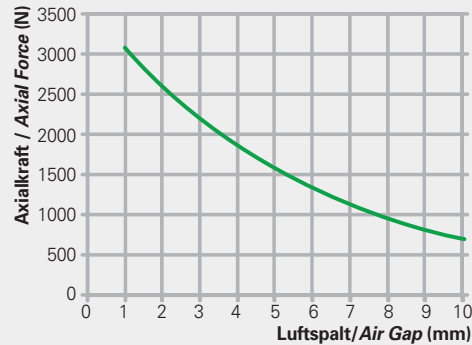
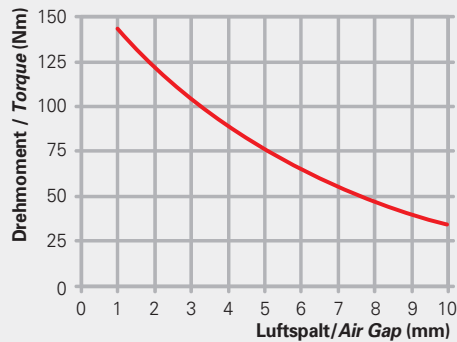

| Luftspalt<br>Air Gap<br>mm | Drehmoment<br>Torque<br>Nm | Axialkraft<br>Axial Force<br>N |
|----------------------------|----------------------------|--------------------------------|
| <b>1</b>                   | 146,0                      | 3114                           |
| <b>2</b>                   | 124,0                      | 2558                           |
| <b>3</b>                   | 104,0                      | 2180                           |
| <b>4</b>                   | 87,5                       | 1875                           |
| <b>5</b>                   | 75,0                       | 1601                           |
| <b>6</b>                   | 63,5                       | 1334                           |
| <b>7</b>                   | 54,0                       | 1134                           |
| <b>8</b>                   | 47,0                       | 956                            |
| <b>9</b>                   | 41,0                       | 800                            |
| <b>10</b>                  | 35,0                       | 689                            |

Technische Änderungen vorbehalten  
We reserve the right to make technical alterations