

MTD-40

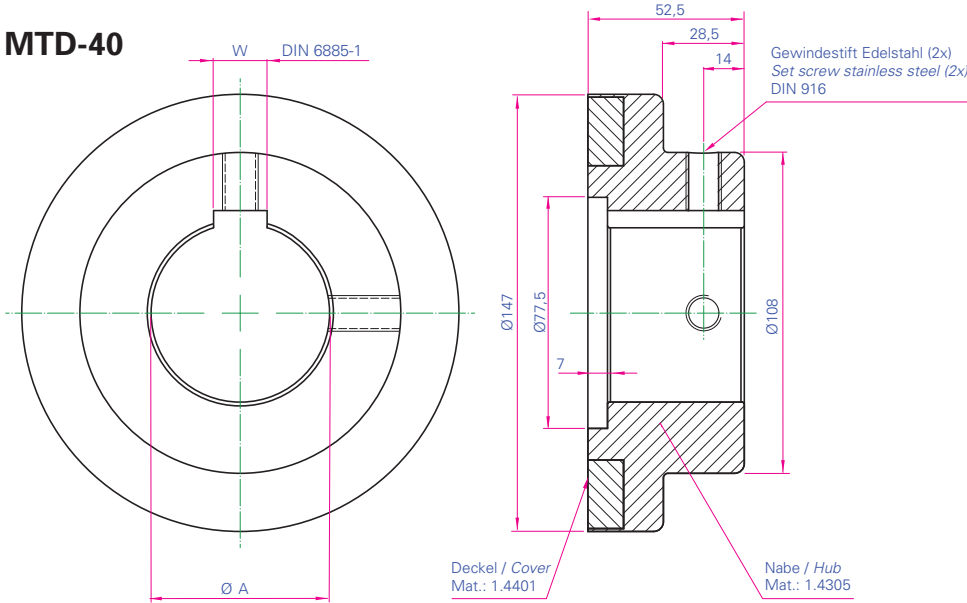

Technische Daten
Technical Specifications

| Typ Type | Max. Geschw Speed (rpm) | Gewicht pro Hälfte Weight per Hub (kg) |
|---------------|-------------------------------|--|
| MTD-40 | 7800 | 4,1 |

| Typ Type | Bohrung Bore Ø A (mm) | Passfeder Keyway W (mm) | Gewindestift Set Screw |
|------------------|-----------------------------|-------------------------------|---------------------------|
| MTD-40-25 | 25H7 | 8 | M 8 |
| MTD-40-30 | 30H7 | 8 | M 8 |
| MTD-40-35 | 35H7 | 10 | M 8 |
| MTD-40-40 | 40H7 | 12 | M 8 |
| MTD-40-45 | 45H7 | 14 | M12 |
| MTD-40-50 | 50H7 | 14 | M12 |
| MTD-40-55 | 55H7 | 16 | M12 |
| MTD-40-60 | 60H7 | 18 | M12 |

Leistungsdaten
Performance Data
MTD-40

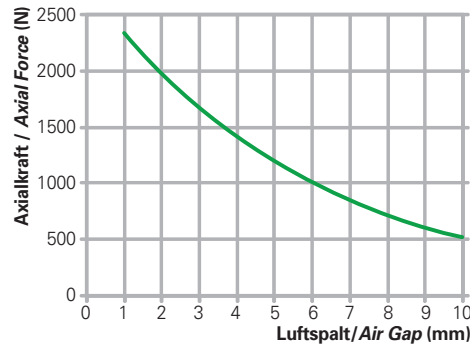
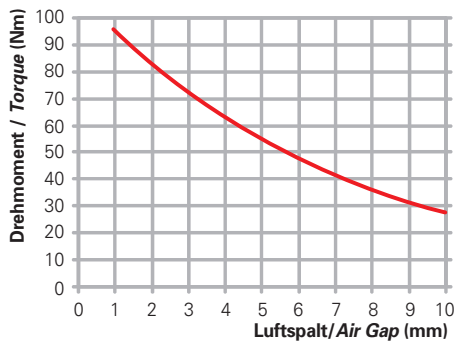

| Luftspalt Air Gap mm | Drehmoment Torque Nm | Axialkraft Axial Force N |
|----------------------------|----------------------------|--------------------------------|
| 1 | 95,0 | 2370 |
| 2 | 84,0 | 2000 |
| 3 | 73,0 | 1663 |
| 4 | 63,0 | 1400 |
| 5 | 54,0 | 1177 |
| 6 | 47,0 | 1000 |
| 7 | 41,0 | 842 |
| 8 | 36,0 | 715 |
| 9 | 31,5 | 612 |
| 10 | 28,0 | 520 |